

(D) Vor Montage bitte Gebrauchsanleitung lesen!

(GB) Please read the instructions of use prior to starting installation work!

(F) Prière de lire le mode d'emploi avant de procéder au montage !

(I) Prima del montaggio leggere per favore le istruzioni per l'uso!

(NL) Lees voor de montage de gebruiksaanwijzing door

(PL) Przed przystąpieniem do montażu przeczytaj instrukcję użytkowania!

# DSB2 / V-BADS2 / DSB2F

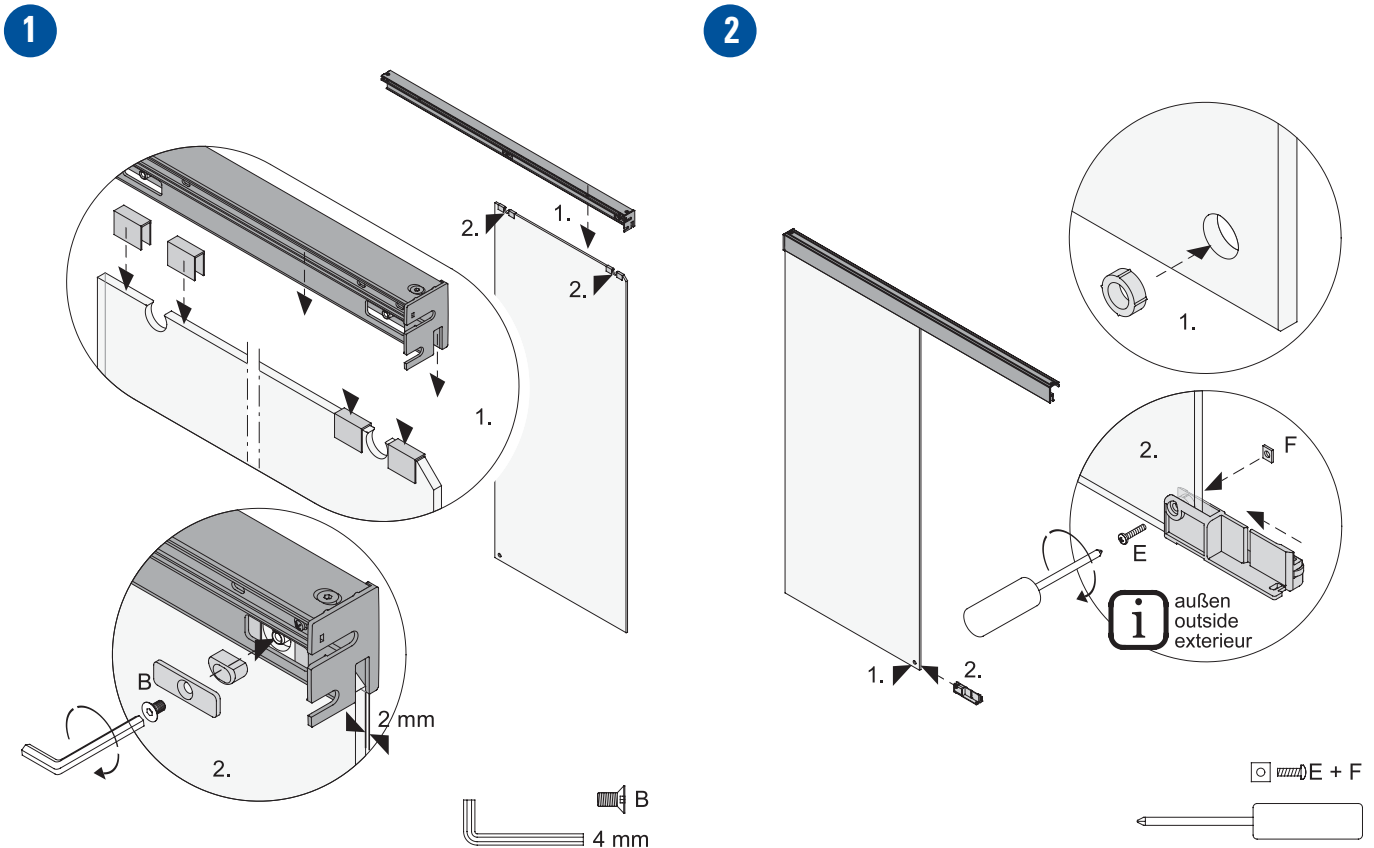
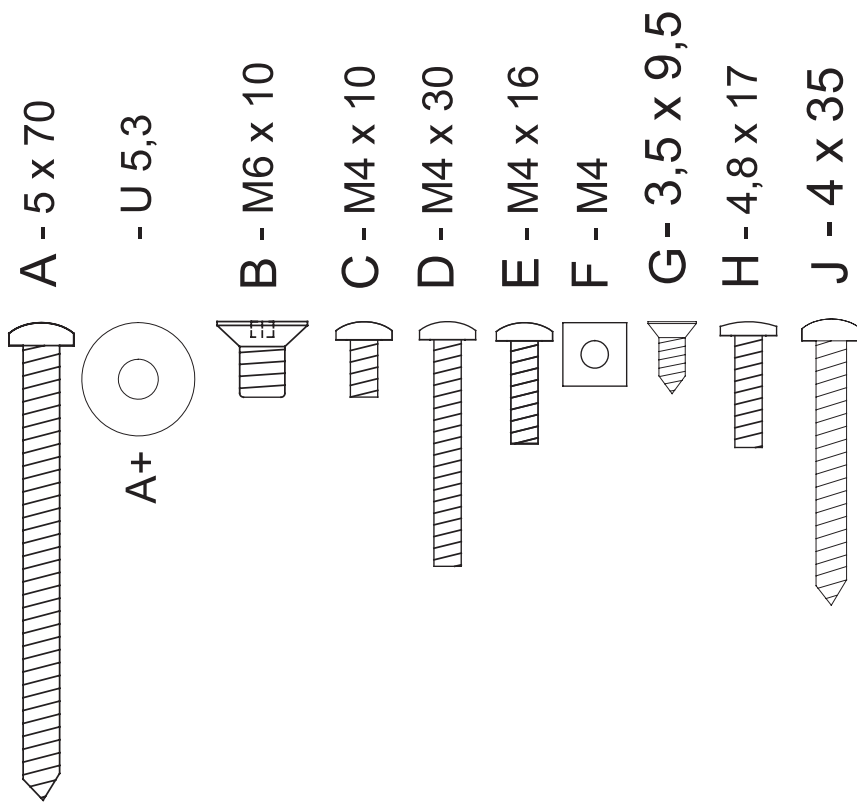

3

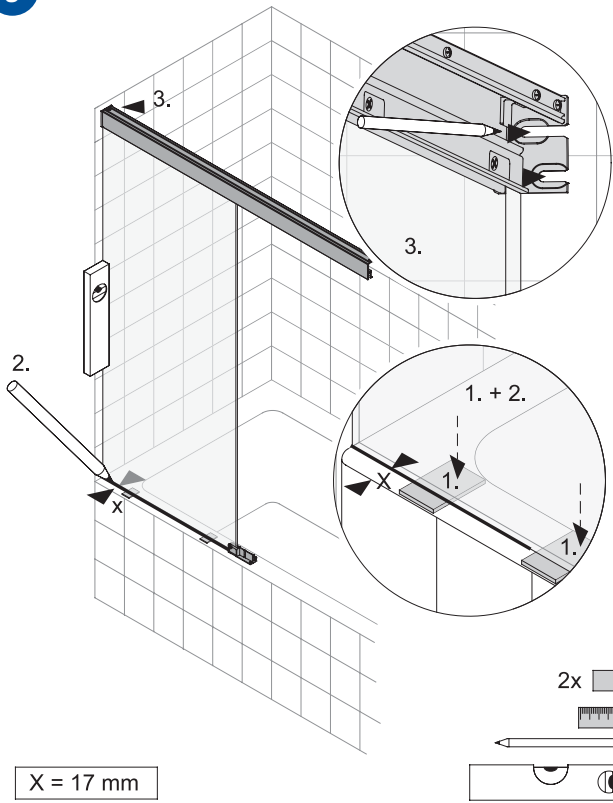

4

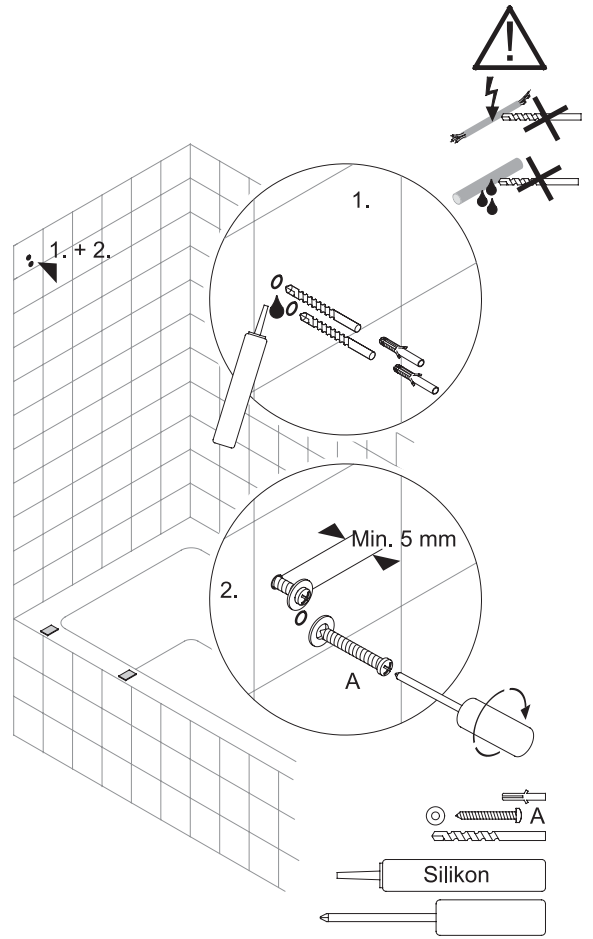

5

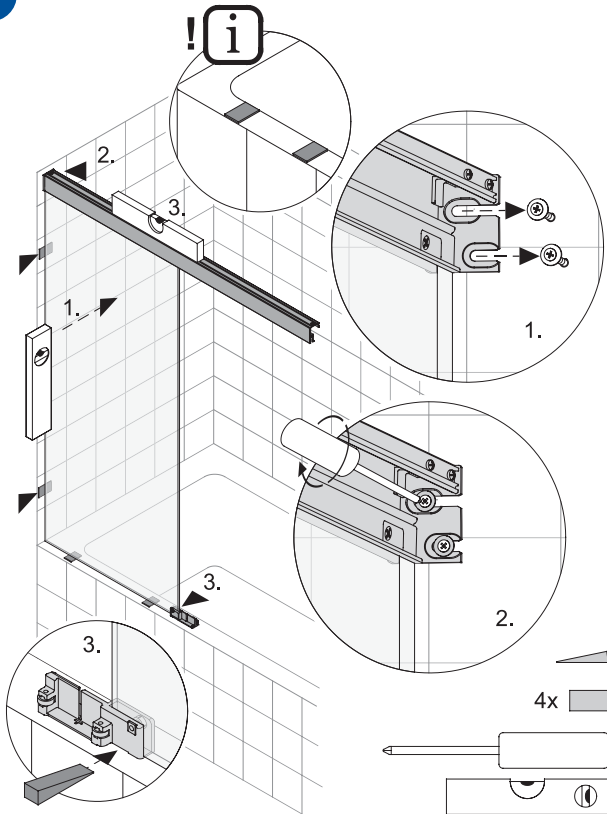

6

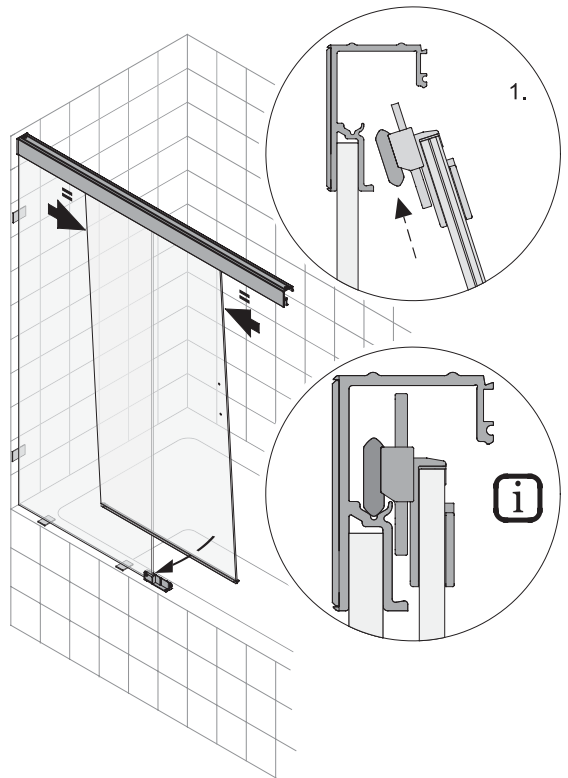

# Softclose

7

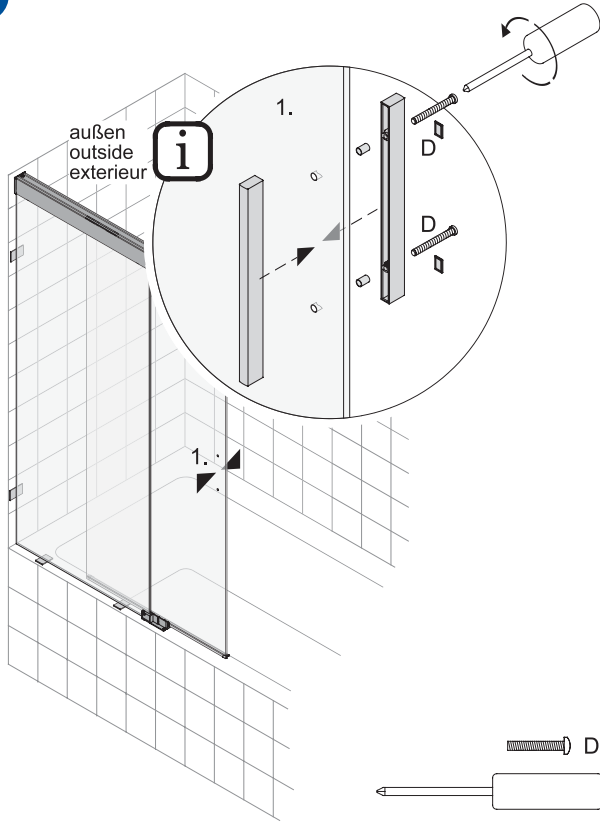

8

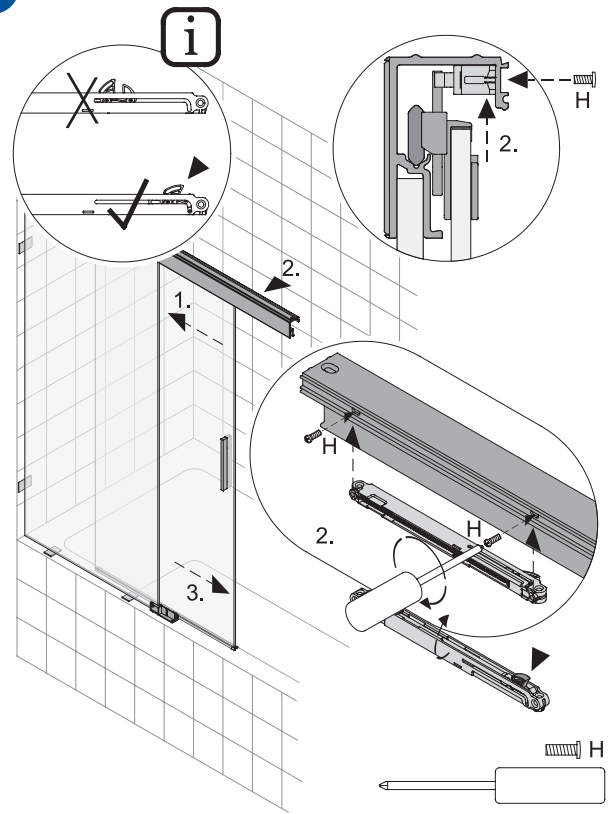

9

**i** Einstellmöglichkeit  
adjustment solution  
ajustage solution

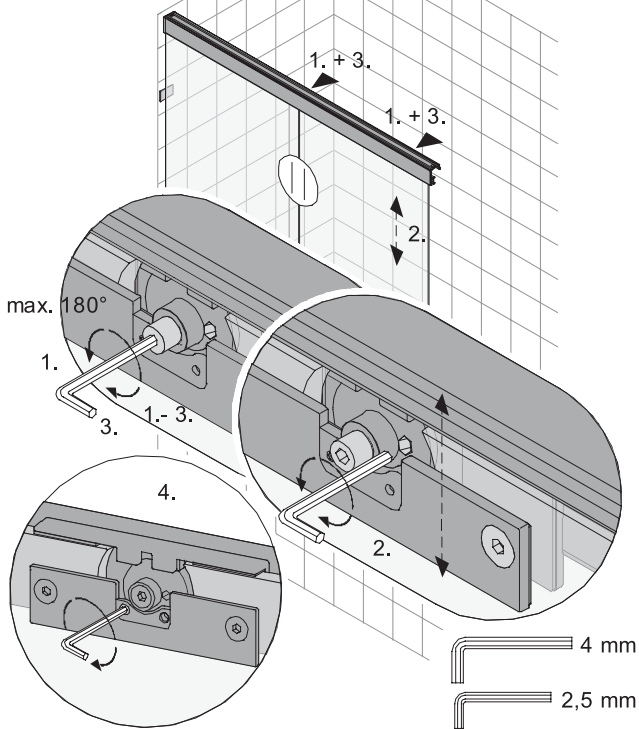

10

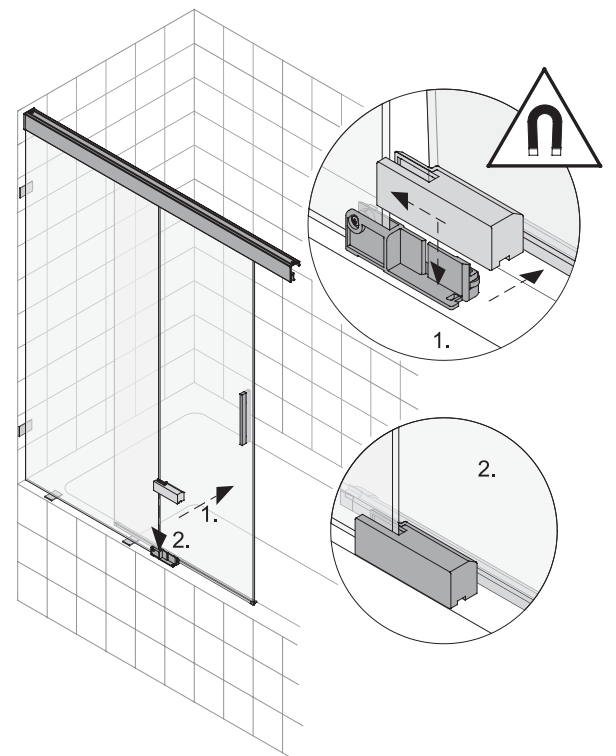

11

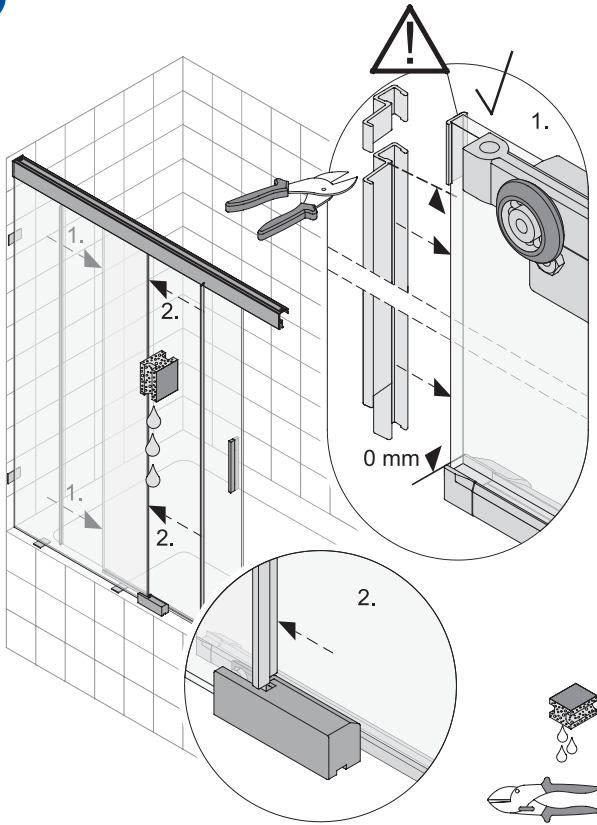

12

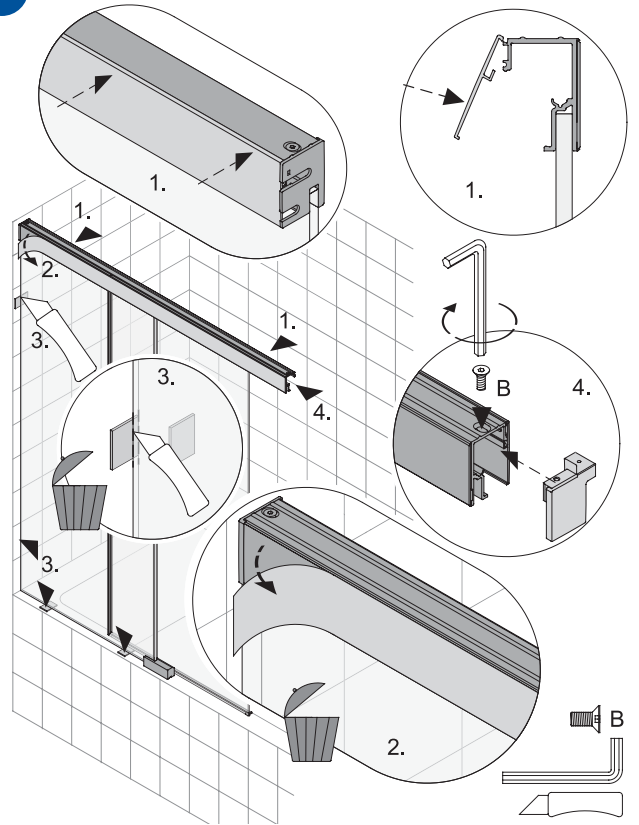

13

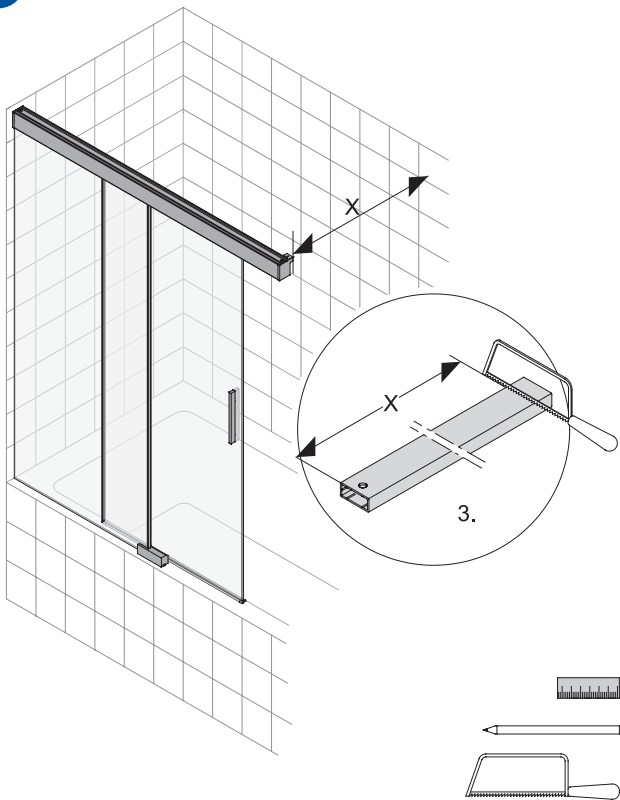

14

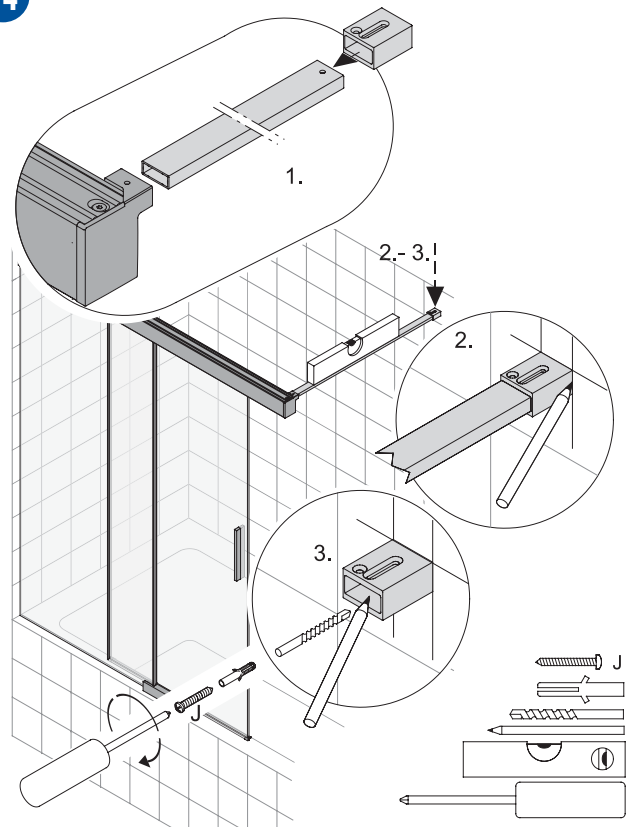

15

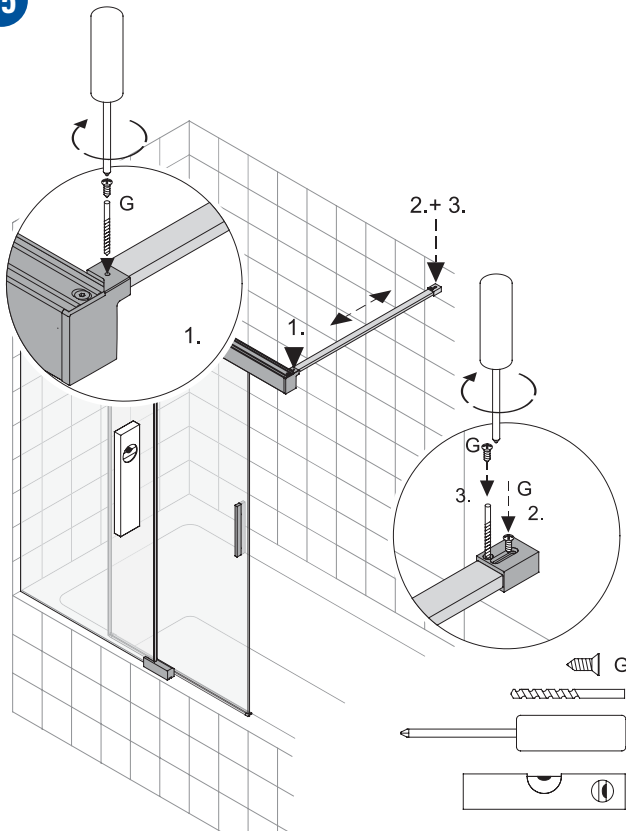

16

innen / inside / interieur

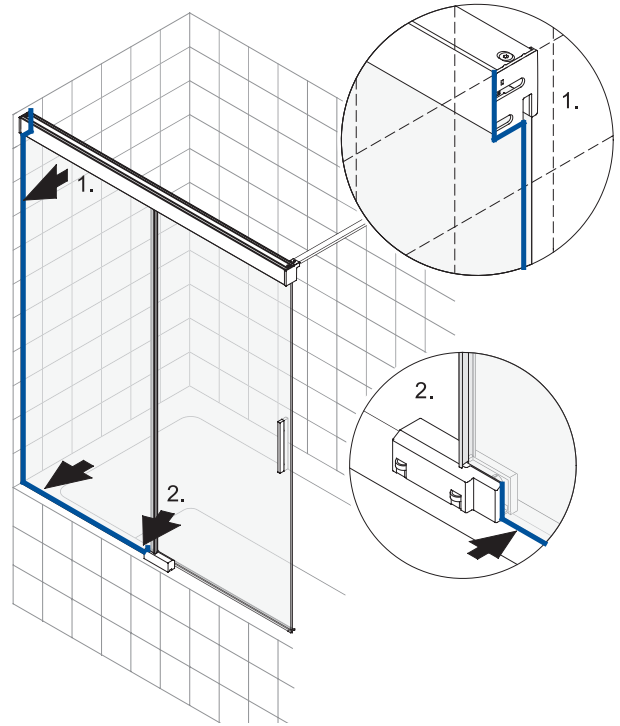

17

außen / outside / extérieur

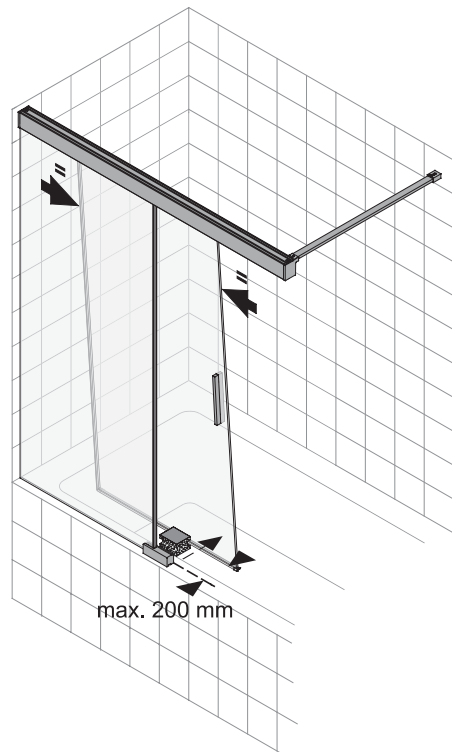
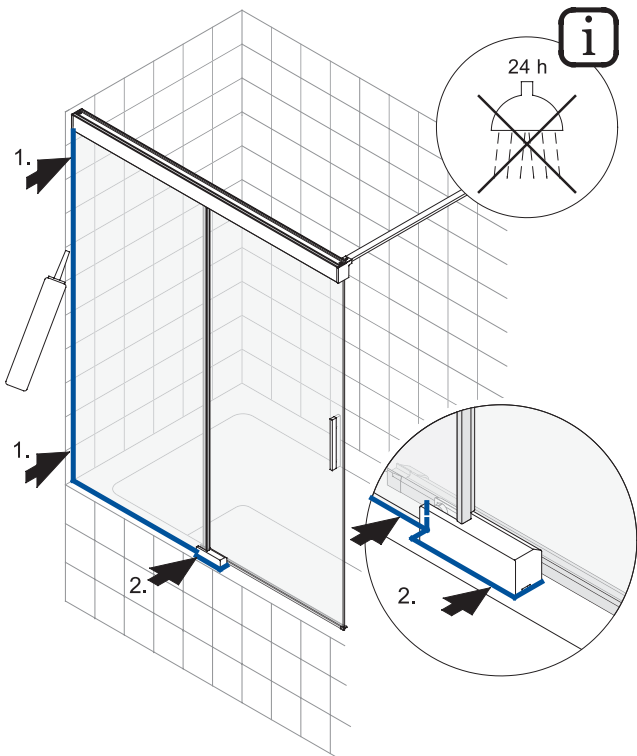

# DSB2 / V-BADS2 / DSB2F - L

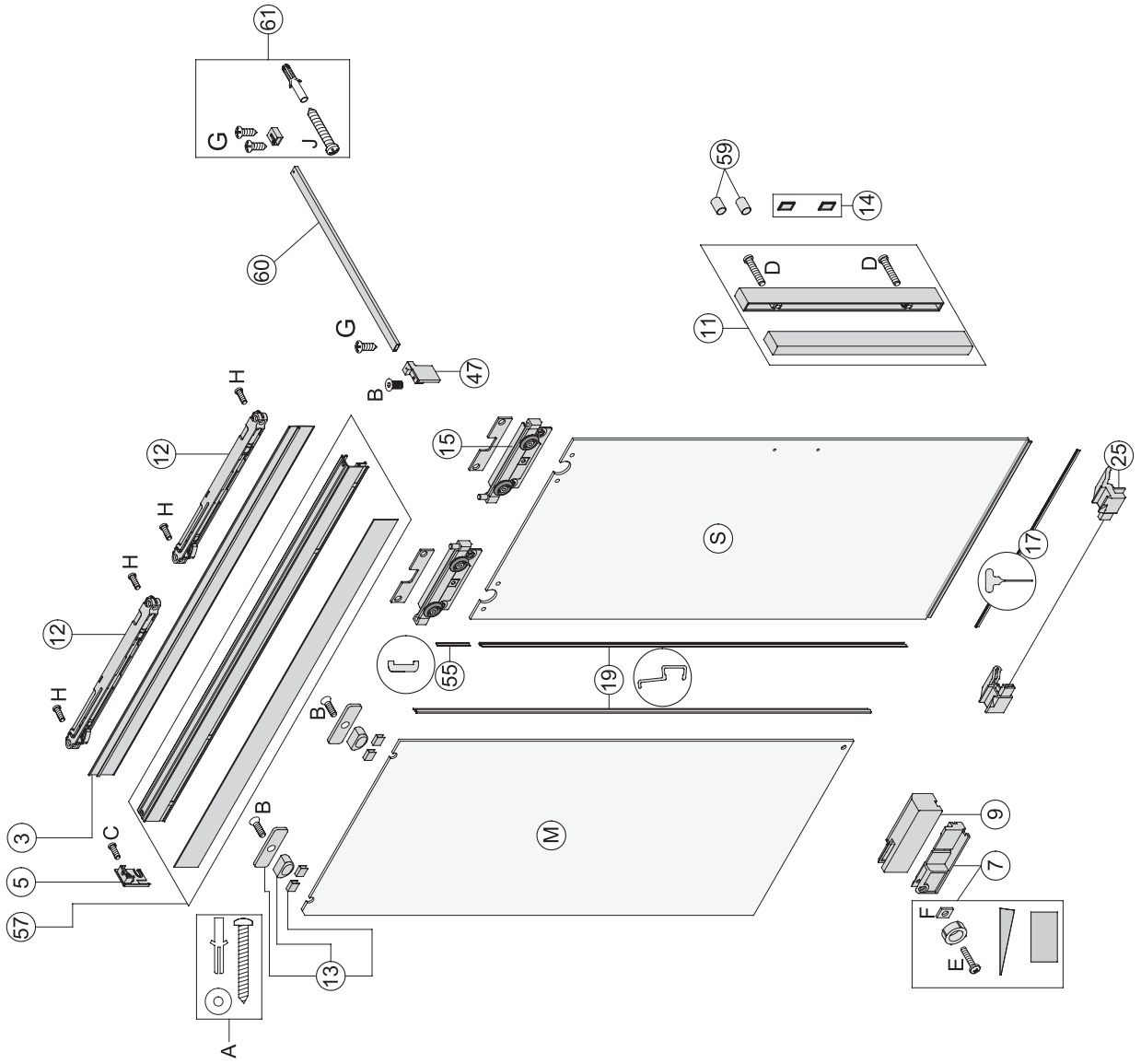

# DSB2 / V-BADS2 / DSB2F-R

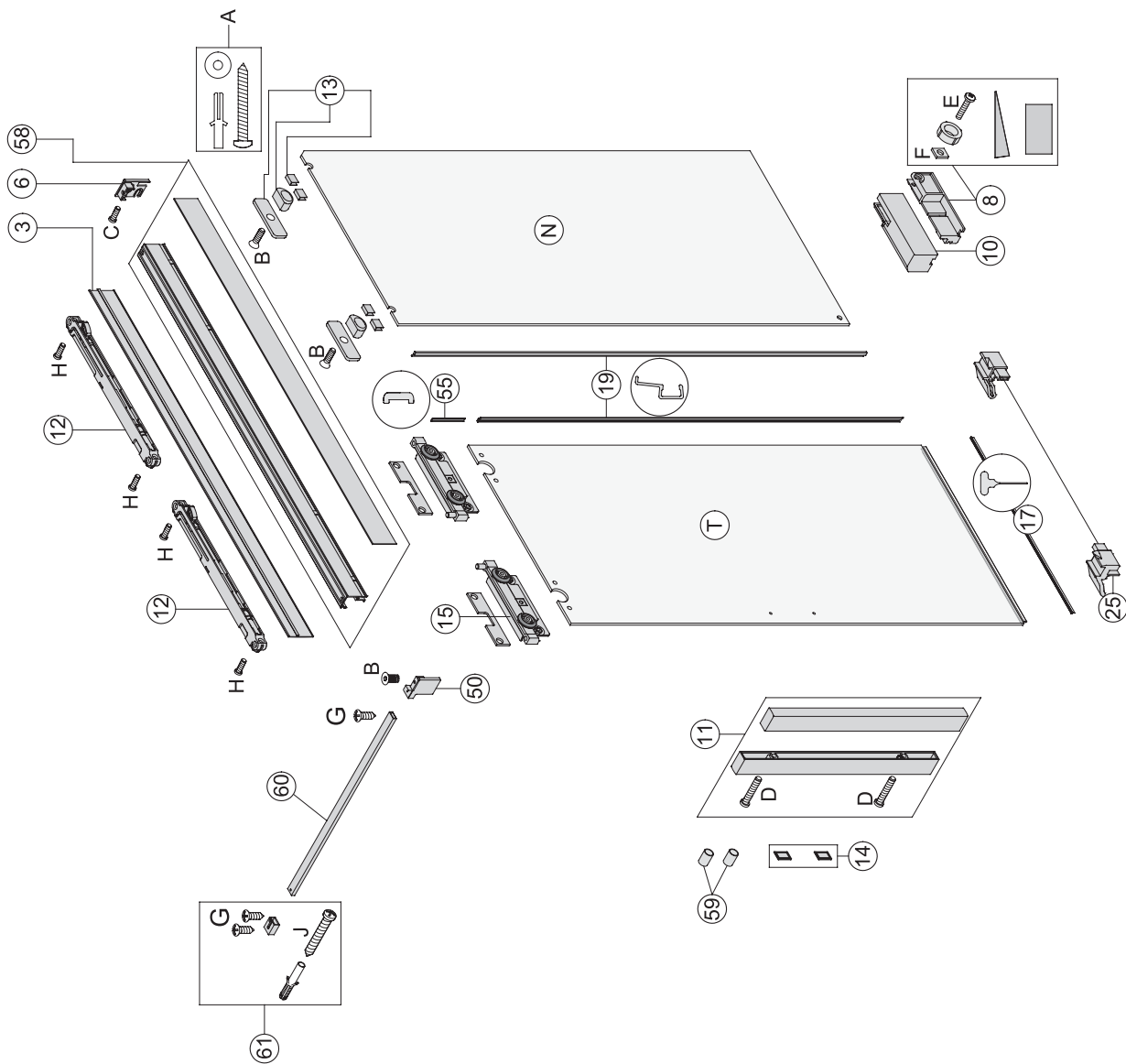

 PIN: 0000  
 123456789012345678  
 123456789012 ⇒ Ersatzteil / spare part / Pièce de rechange / Onderdeel / Część zamienna / Parte di ricambio

Ci riserviamo il diritto di apportare modifiche tecniche senza obbligo di preavviso. Decliniamo ogni responsabilità per errori in fase di stampa riguardanti i nostri prodotti e/o loro specifiche tecniche.

Nous nous réservons le droit de procéder à des modifications techniques. Nous n'assurons pas de responsabilité pour des erreurs techniques ou des fautes d'impression.

Technische Veranderingen voorbehouden. Voor drukfouten en technische vergissingen stellen wij ons niet aansprakelijk.

We reserve the right to technical amendments. We do not take responsibility for printing errors or technical confusions.

Technische Änderungen behalten wir uns vor. Für Druckfehler oder technische Verwechselungen übernehmen wir keine Gewähr.