

(D) Vor Montage bitte Gebrauchsanleitung lesen!

(F) Prière de lire le mode d'emploi avant de procéder au montage!

(I) Prima del montaggio leggere per favore le istruzioni per l'uso!

(GB) Please read the instructions of use prior to starting installation work!

**DE**

Duschkabinen sind zur Montage auf Duschwannen bestimmt. Bei anderweitiger Verwendung ist ein gleichwertiger Duschbereich (Abdichtung zum Estrich, Gefälle, ...) sicherzustellen. Bei Montage auf Fuge ist bauseits sicherzustellen, dass es sich um eine wartungsfreie wasserdichte Verfugung handelt. Bei bodenfreier und bodenferner Montage sind bauseits Maßnahmen gegen die Rutschgefahr vor der Duschkabine zu treffen. Vor dem Bohren der Dübellöcher die Wand auf darunterliegende Versorgungsleitungen (Strom-, Gas- und Wasserleitungen) prüfen. Das Anbohren derartiger Leitungen stellt eine Gefahr für Leben und Sachwerte dar! Duschkabinen sind zur Montage an massiven Wänden und Decken bestimmt. Bei anderweitiger Verwendung ist bauseits für entsprechende Stabilität (z. B. durch Spezialdübel) zu sorgen. Bitte verwenden Sie das für Ihren Einsatzfall geeignete Silikon (z. B. für Marmor).



Vor dem Einbau Duschkabine sofort auf Transportschäden oder anderweitige Beschädigungen prüfen. Ganz wesentlich für Ihre eigene Sicherheit ist die Prüfung der Glasteile. Auch geringfügige Beschädigungen können zu Glasbruch führen.



Deshalb dürfen Sie auch bei Montage und Benutzung der Duschkabine die Glaskanten nicht beschädigen! Transportschäden können nach Einbau nicht mehr anerkannt werden, ebenso Schäden und Kosten durch unsachgemäße Montage, Pflege und Wartung.

**Persönliche Schutzausrüstung empfohlen.****FR**

Les parois de douche ont été conçues pour une pose sur receveur. Pour une autre utilisation il est important que les mêmes conditions soient remplies (étanchéité par rapport à la chape, pente, etc.). Dans le cas d'une pose sur carrelage, les joints des carrelages doivent être parfaitement étanches, notamment s'ils doivent être recouverts par un profilé ou un vitrage. Dans le cas de pose d'une paroi sans profilé bas ou d'une cloison de séparation il faut prendre des mesures pour éviter le risque de dérapage avant la paroi ou la cloison. Avant de percer les trous destinés aux chevilles, s'assurer qu'aucune canalisation d'électricité, d'eau et de gaz ne passe dans le mur à cet endroit. Il est très dangereux de percer de telles canalisations et il peut en résulter de graves dommages matériels! Les parois de douche sont conçues pour un montage sur des murs et plafonds massifs (résistants). Pour une autre utilisation il est important que les conditions de stabilité sur place soient suffisantes (p. ex. utilisation de chevilles spéciales). Employez le silicone en fonction de la nature des matériaux (p. ex. silicone pour marbre).



Vérifier si la paroi a subi des dommages liés au transport ou d'autres dégâts avant la pose de la paroi de douche. Il est essentiel, pour votre sécurité, d'examiner minutieusement les panneaux en verre, car même de légères détériorations peuvent causer ultérieurement un bris de glace.



Par conséquent les bords du vitrage ne doivent être endommagés ni lors de la pose, ni lors de l'utilisation de la paroi de douche. D'éventuels dommages de transport ne peuvent plus être garantis après la pose de la paroi de douche. Il en est de même pour les dommages et les coûts qui sont dus à une pose, un nettoyage ou un entretien non adéquats.

**Port de lunettes et de gants de protection obligatoire!****IT**

I box doccia sono concepiti per il montaggio su vasche da bagno. In caso di impiego diverso è necessario garantire un'equivalente area doccia (impermeabilizzazione sul pavimento, pendenza, ecc...). In caso di montaggio su giunzioni bisogna assicurarsi che si tratta di fughe impermeabili e che non necessitano di manutenzione. In caso di montaggio sospeso e distante dal pavimento devono essere prese delle misure contro il rischio di scivolamento davanti al box doccia. Prima di eseguire i fori per tasselli controllare se nella parete vi sono delle condutture di alimentazione (per corrente, gas e acqua). La perforazione di tali condutture costituisce un pericolo per la vita e gli oggetti! I box doccia sono concepiti per il montaggio su pareti e soffitti robusti. In caso di impiego diverso è necessario garantire nel locale un'adeguata stabilità (per es. mediante tasselli speciali). Si prega di utilizzare il silicone adatto all'impiego (per es. per marmi).



Prima del montaggio controllare subito se il box doccia presenta danni dovuti al trasporto o altri tipi di danni. Molto importante per la propria sicurezza è il controllo delle parti in vetro. Anche i minimi danni possono causare la rottura dei vetri.



Per questo motivo, gli spigoli in vetro non devono essere danneggiati neanche durante il montaggio e l'uso del box doccia! Dopo il montaggio, i danni dovuti al trasporto non possono essere più riconosciuti; lo stesso vale per i danni e i costi dovuti a un montaggio, una cura e una manutenzione inadeguati.

**Si raccomanda l'utilizzo di indumenti protettivi personali!****GB**

Shower enclosures are intended for installation on shower trays. If installing without a shower tray, the floor on which the shower enclosure will rest must be flat and level. If installing on a joint or uneven surface, you must ensure this is properly siliconed to form a waterproof and maintenance-free seal. When assembled off-floor or with a step, you must take appropriate measures to prevent slip hazards on entry and exit. Before drilling the raw plug holes, the wall has to be tested for concealed service pipes (electricity-, gas- or water pipes). Drilling into these pipes is a life threatening hazard as well as damage to property. Shower enclosures should be installed on solid walls and bases. If installing on non-solid walls and bases, you must ensure appropriate stability on site (e.g. by using special raw plugs). Please use adequate and correct silicone appropriate for the installation (e.g. for marble).



Prior to installation please carefully examine shower enclosure for transport or other damage. Thorough examination of all glass parts is essential for your own safety. Seemingly minor damage may cause breakage of glass and for this reason, extra care must be taken not to damage the glass edges of the shower enclosure during installation or use of the shower enclosure.



Claims for transport damage after installation and claims for damage or cost caused by incorrect installation, cleaning and maintenance will not be paid.

**Personal protective equipment recommended !**

Benötigtes Werkzeug (nicht enthalten) / Outils nécessaires (non fourni) / Attrezzi necessari (non inclusa) / tools used (not included)

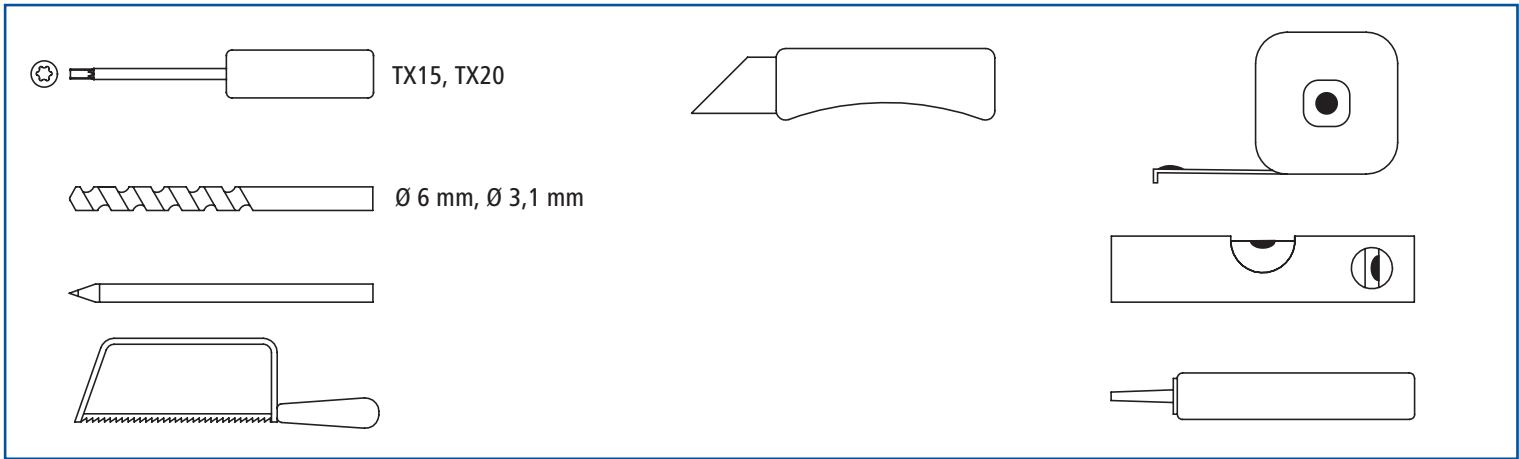

Zubehör / Fittings / Accessori / Accessoires

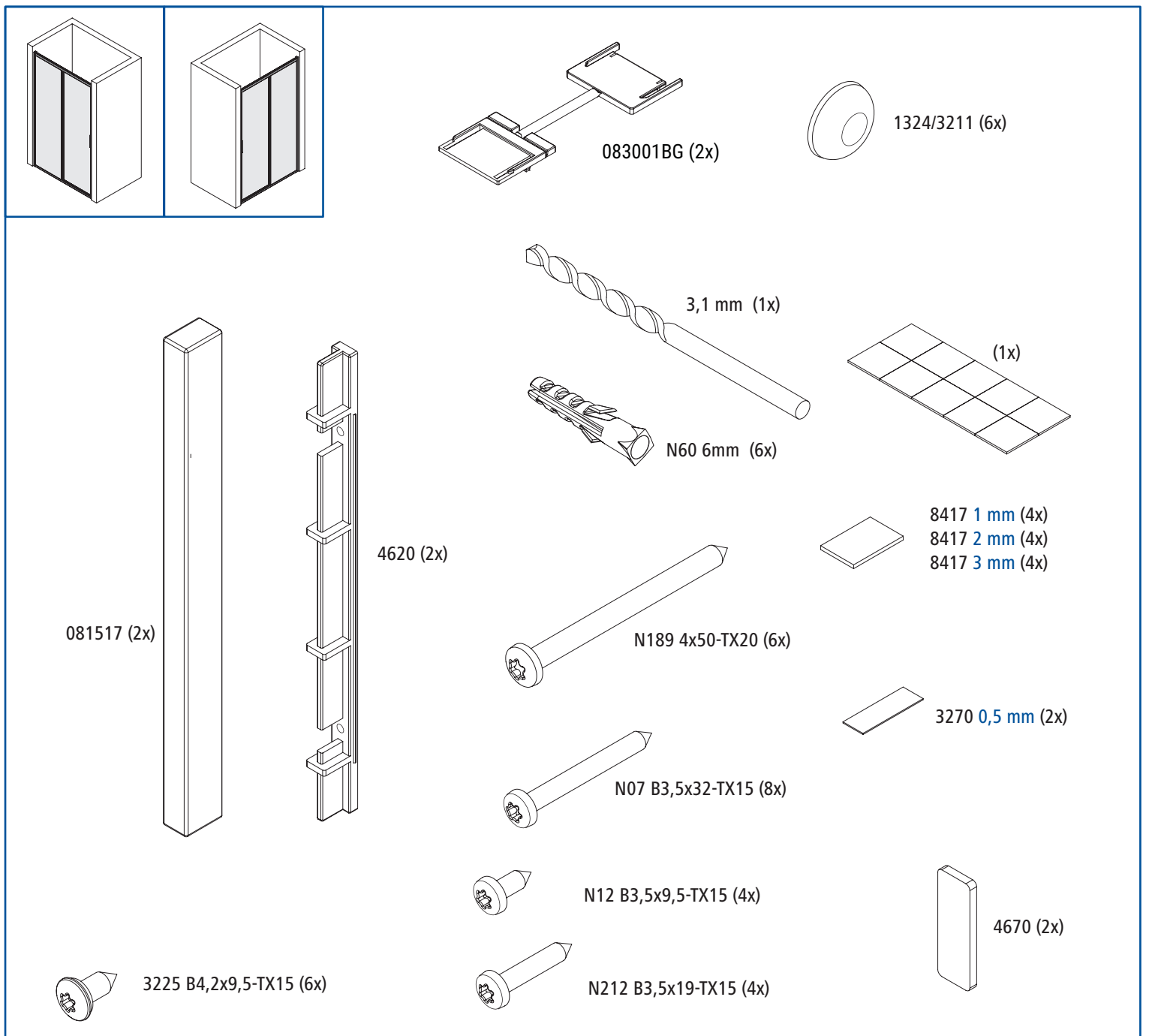



- DE** Achtung! Unsere Glaselemente enthalten Neodymmagnete!
Diese können Magnetdatenträger und Magnetstreifen auf Scheck- und Kreditkarten löschen.
- FR** Attention! Les éléments en verre contiennent en bas des aimants en néodyme!
Ceux-ci peuvent effacer les supports de données magnétiques et les bandes magnétiques sur cartes de crédit et sur cartes bancaires.
- IT** Attenzione! I nostri elementi in vetro contengono magneti al neodimio!
Potrebbero causare la smagnetizzazione dei supporti dati magnetici e delle bande magnetiche presenti su bancomat e carte di credito.
- GB** Attention! The lower sliding elements contain neodymium magnets.
The latter may destroy magnetic data carriers and magnetic strips on cheque and credit cards.



- DE** Achtung! 10 cm Mindestabstand zu Herzschrittmachern und elektronischen Implantaten einhalten!
- FR** Attention! Respectez une distance minimale de 10 cm par rapport aux stimulateurs cardiaques et aux implants électroniques!
- IT** Attenzione! Mantenere una distanza di 10 cm da pacemaker e impianti elettronici!
- GB** Attention! Contain a minimum distance of 10 cm to heart pacemakers and electronic implants!

Achtung! / Attention! / Attenzione! / Attention!

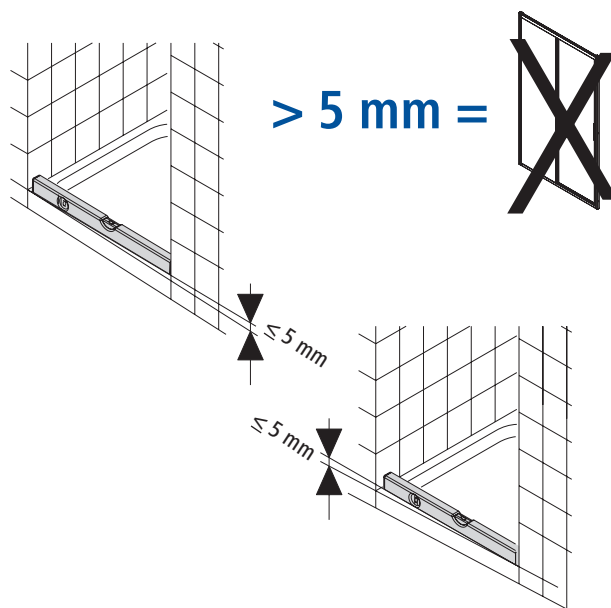
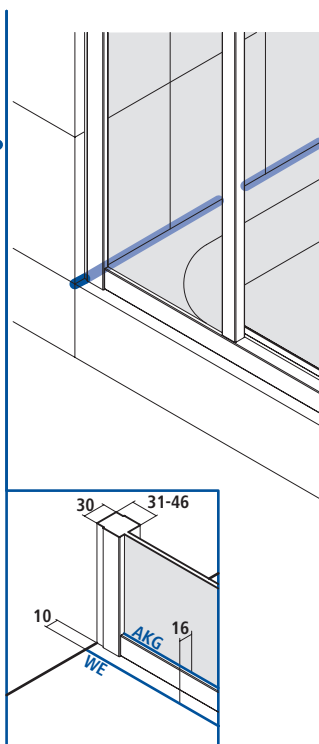

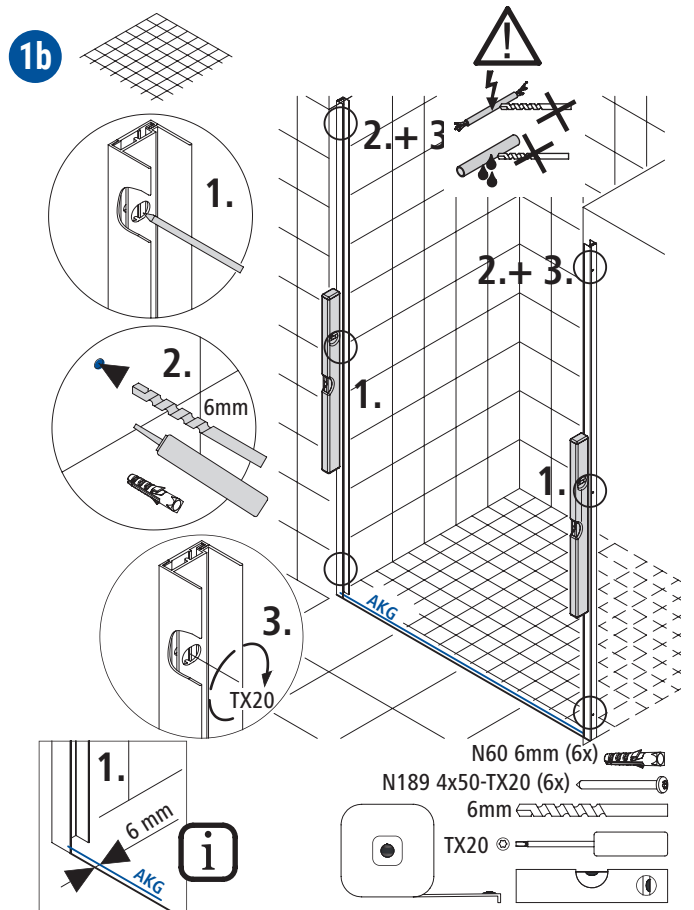
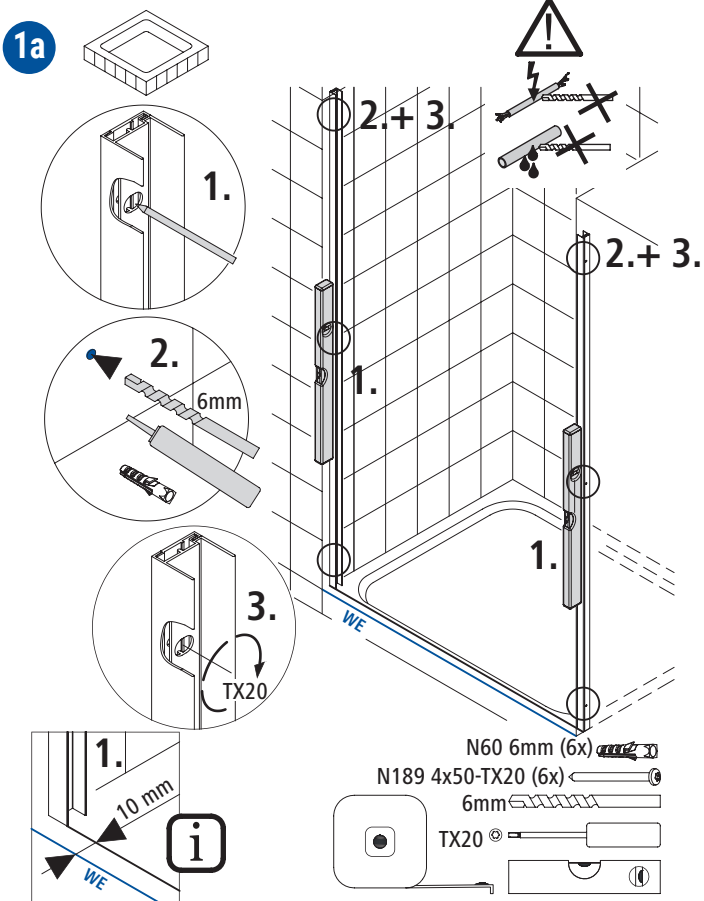
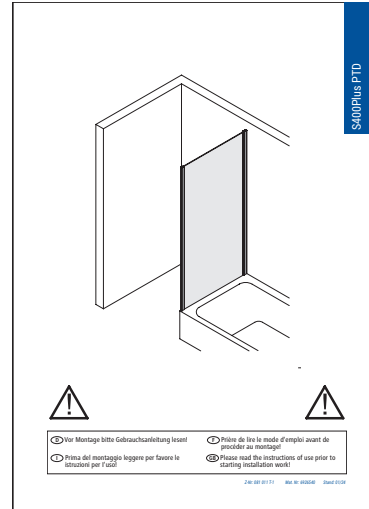
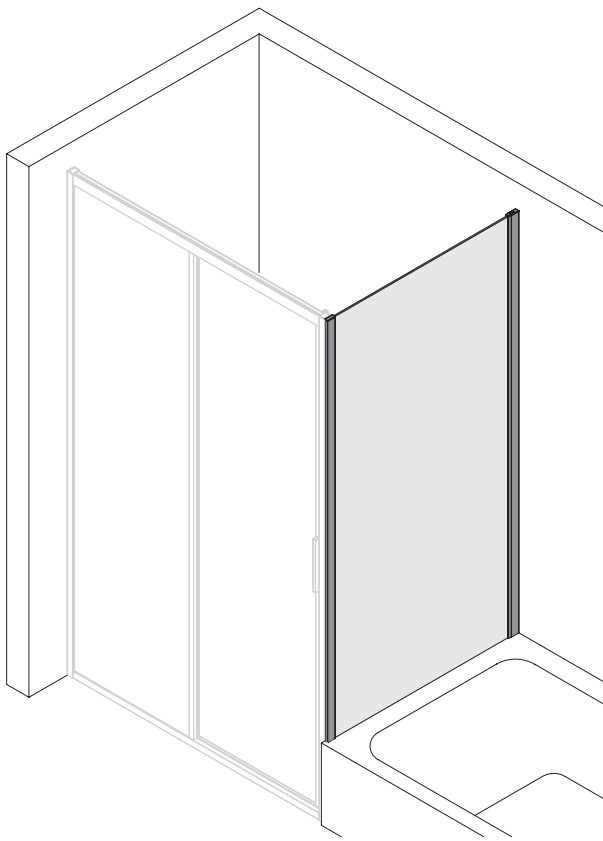

2

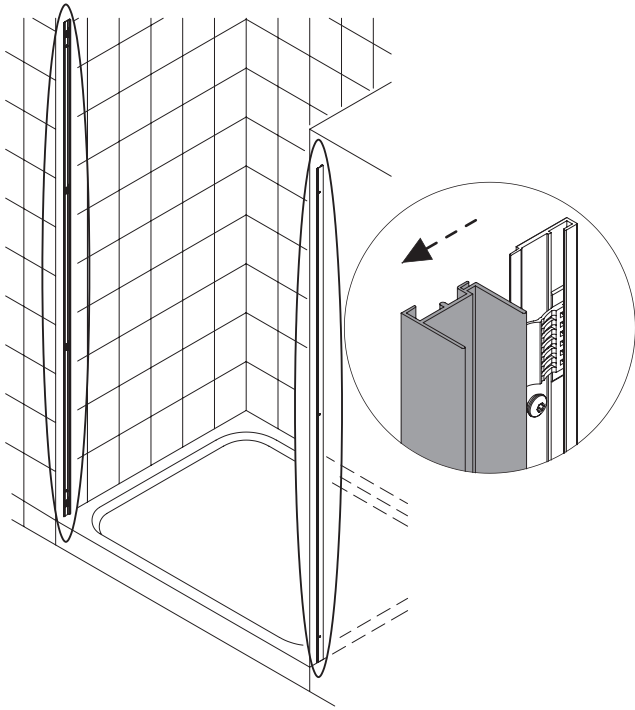

3

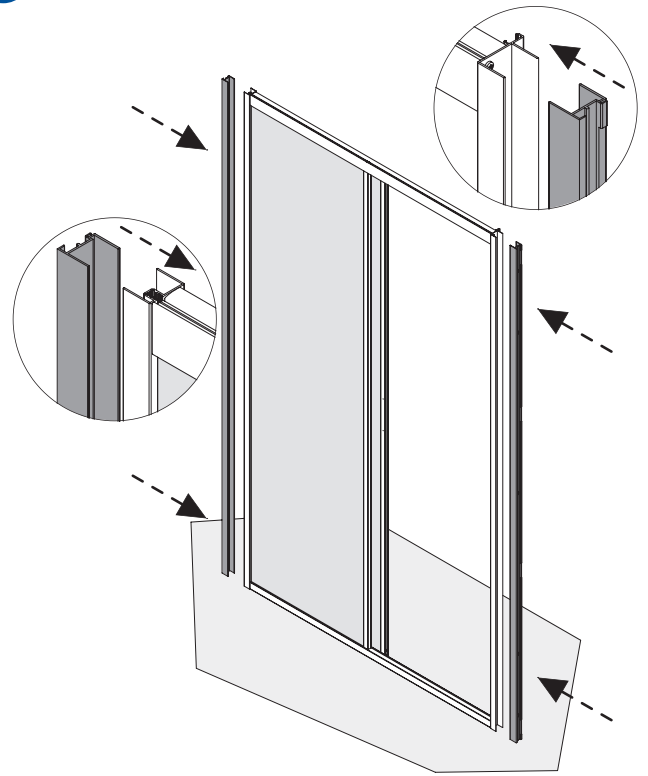

4

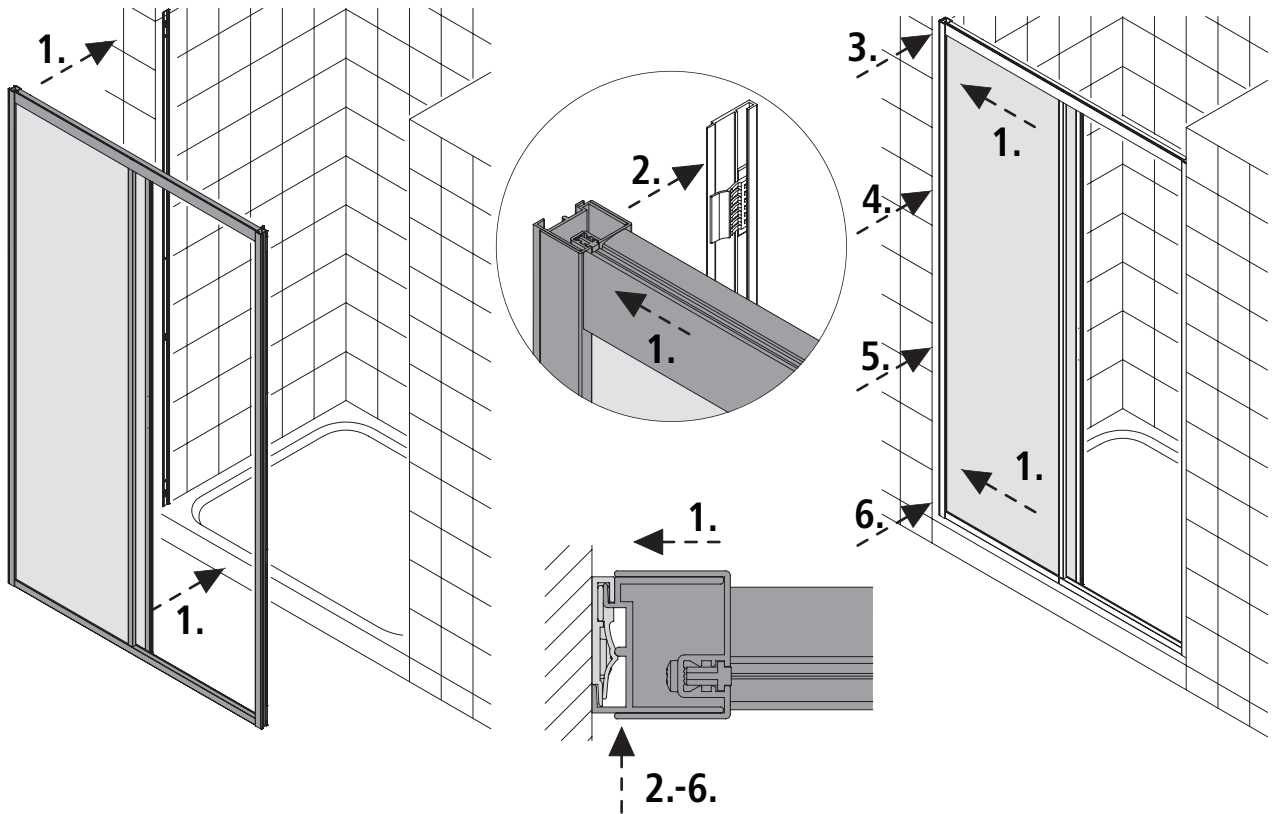

5

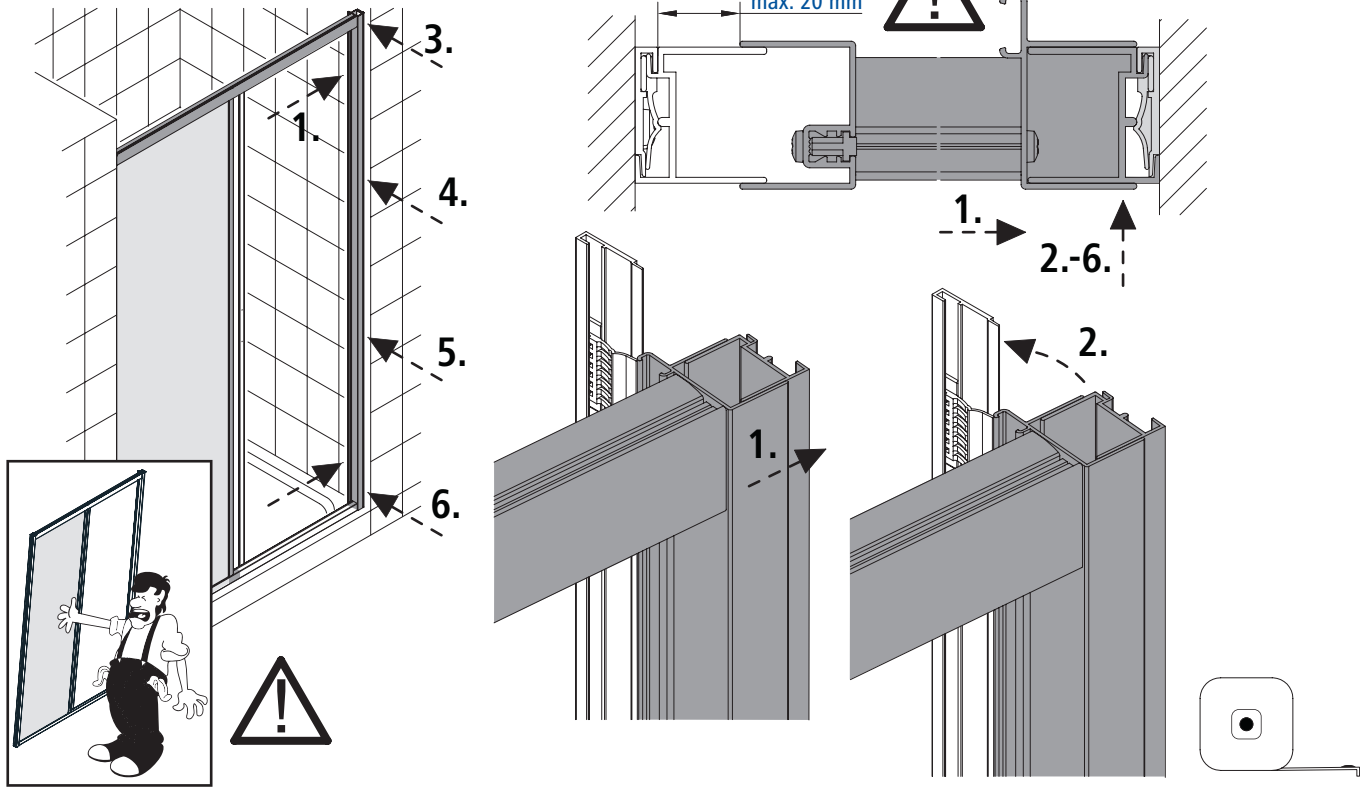

6

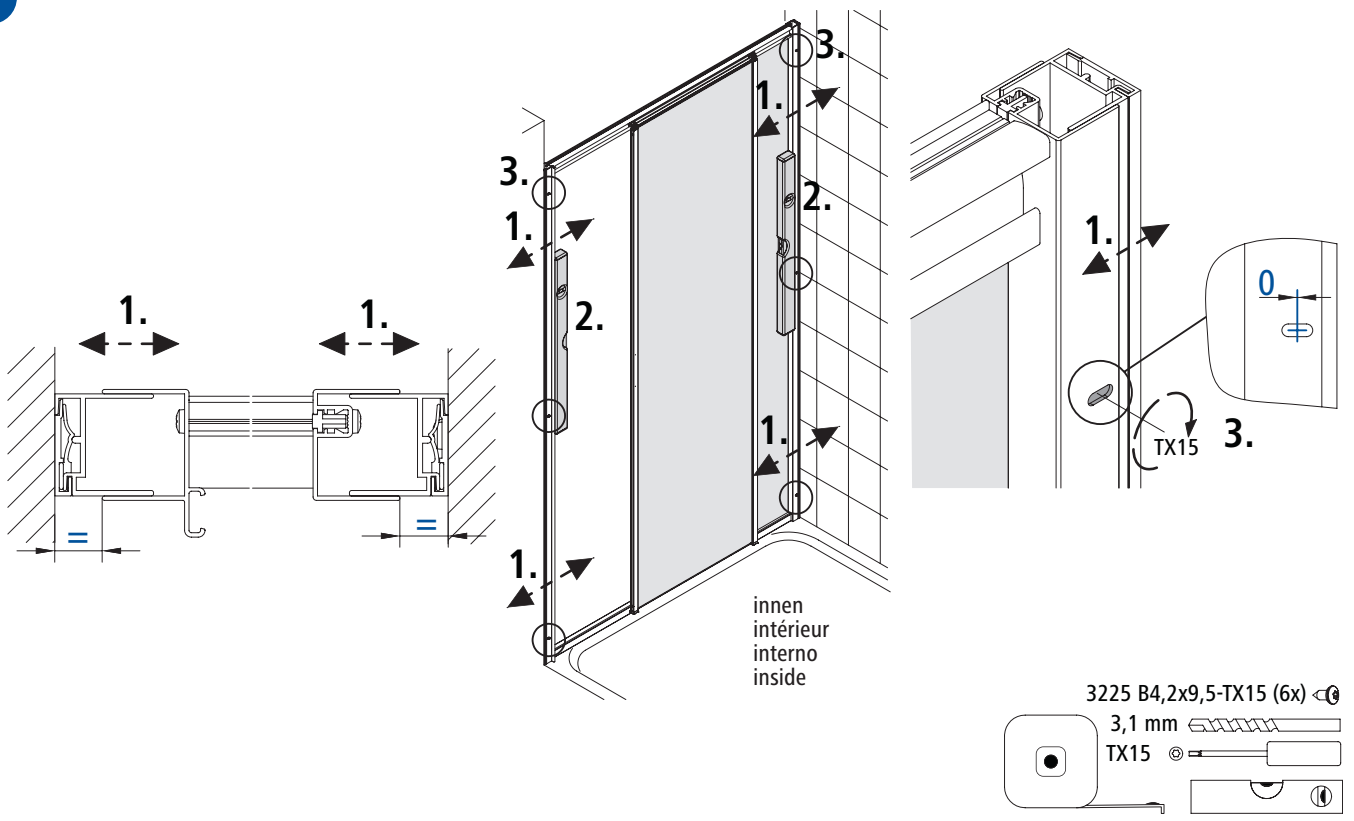

7

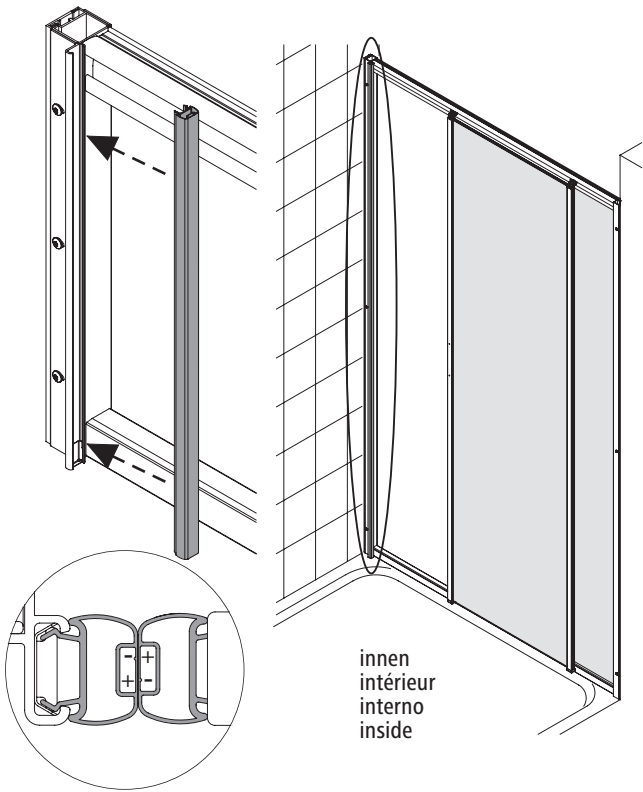

8

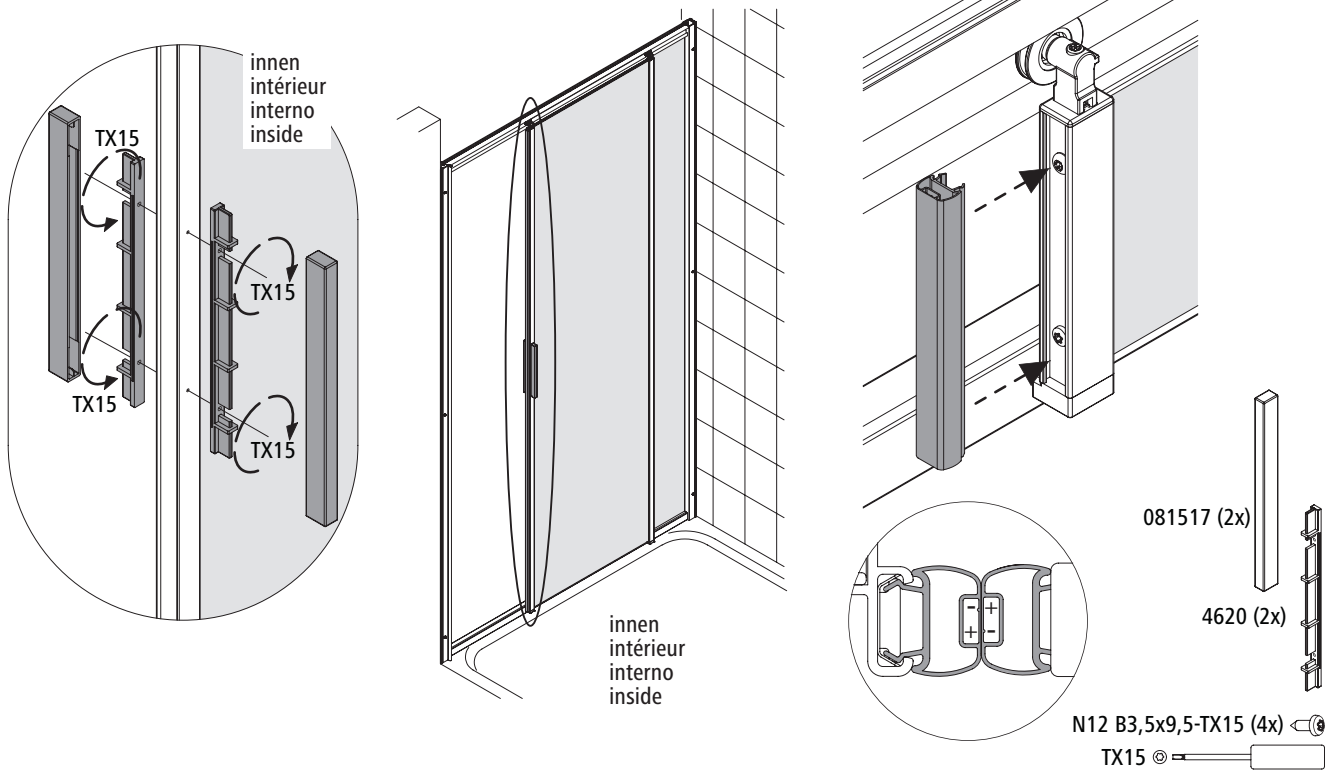

9



Einstellmöglichkeiten
possibilités d'ajustage
possibilità d'aggiustamento
adjustment possibilities

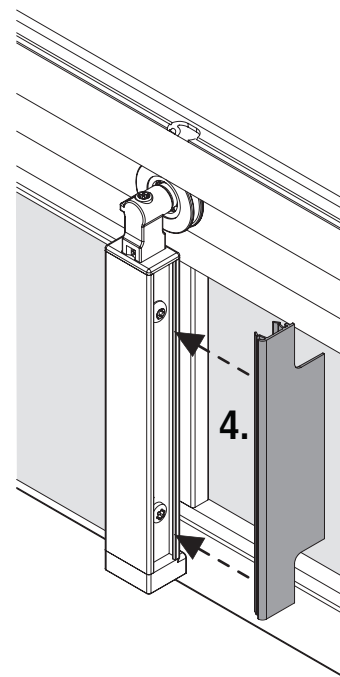
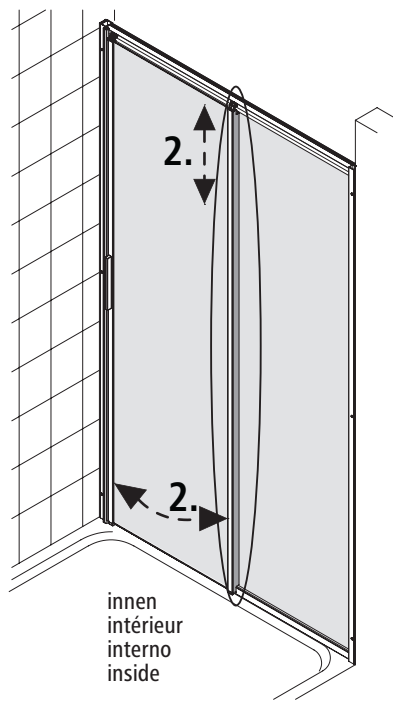
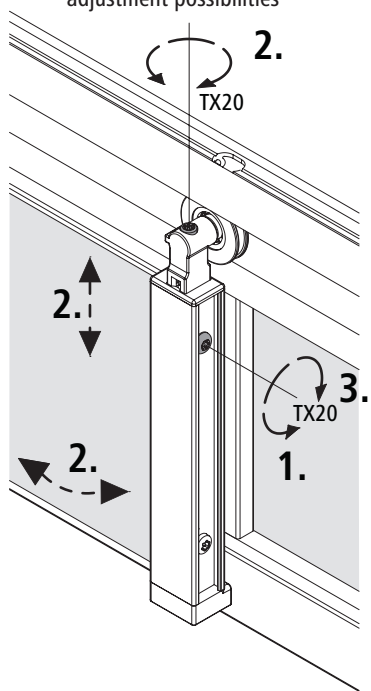

TX20 ©

10



Einstellmöglichkeiten
possibilités d'ajustage
possibilità d'aggiustamento
adjustment possibilities

bei Bedarf
en cas de besoin
in caso di bisogno
if necessary

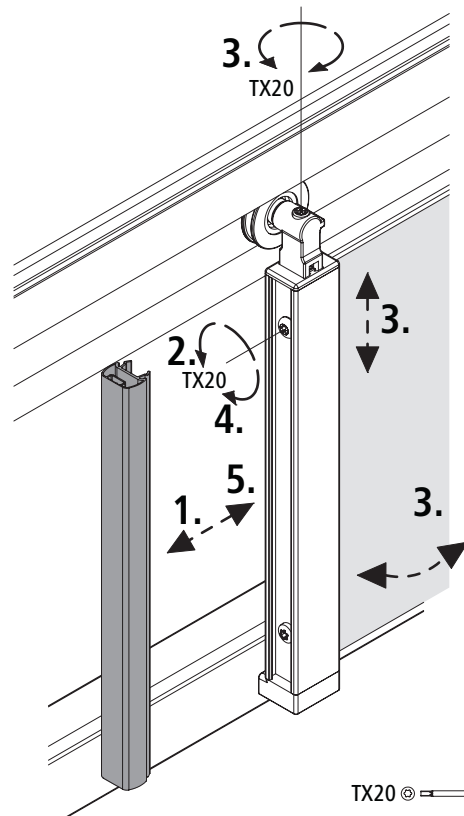
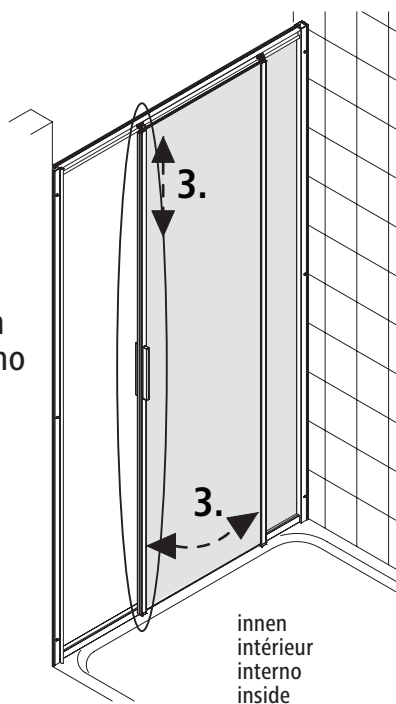

TX20 ©

11

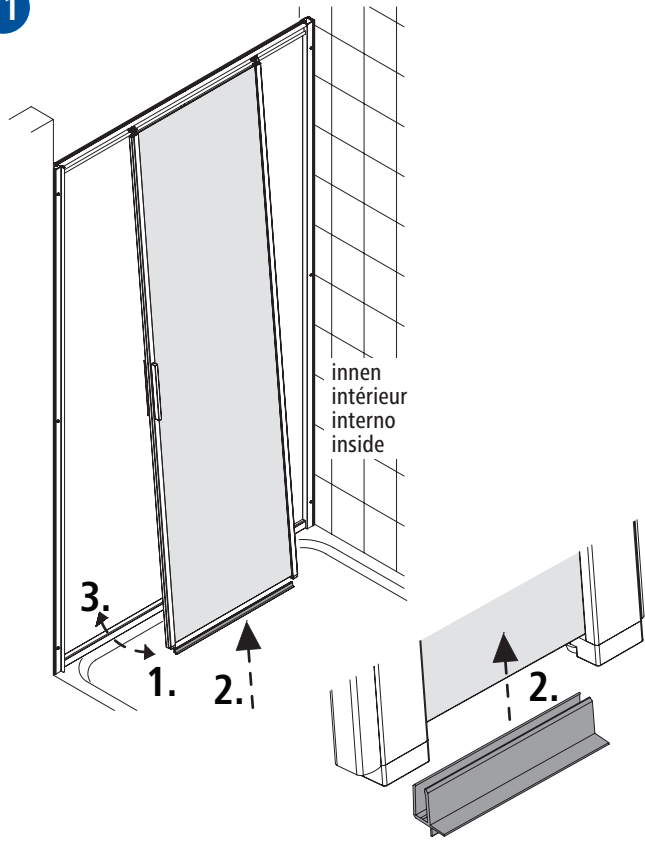

innen
intérieur
interno
inside

12

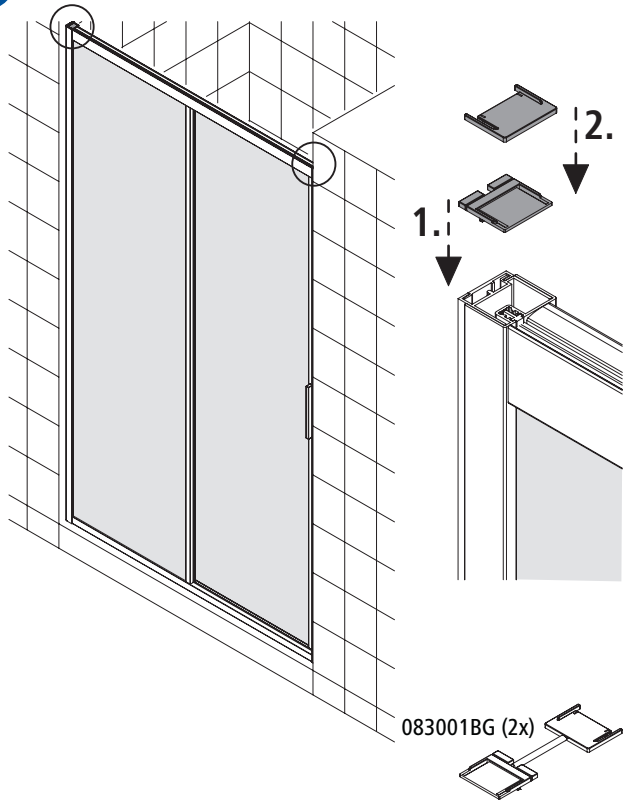

083001BG (2x)

13

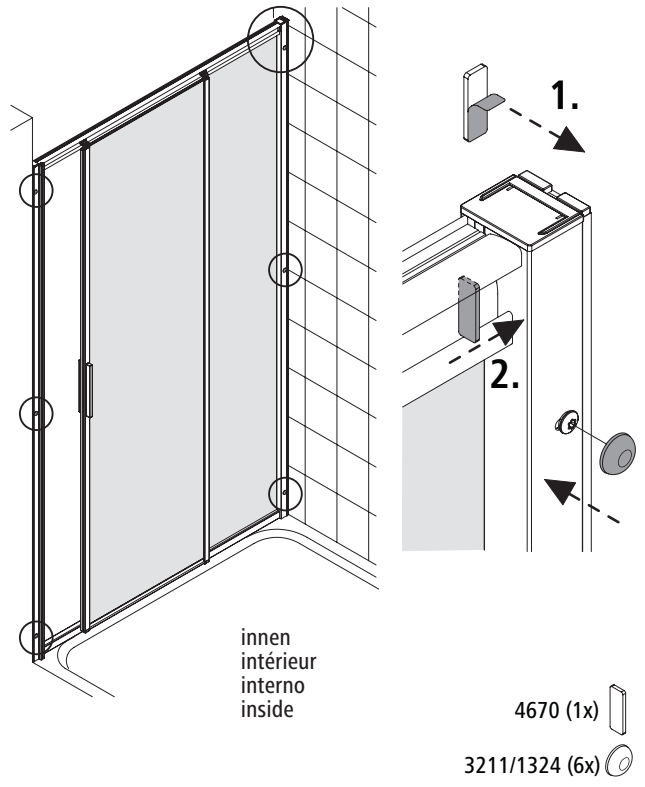

innen
intérieur
interno
inside

4670 (1x)

3211/1324 (6x)

14

